

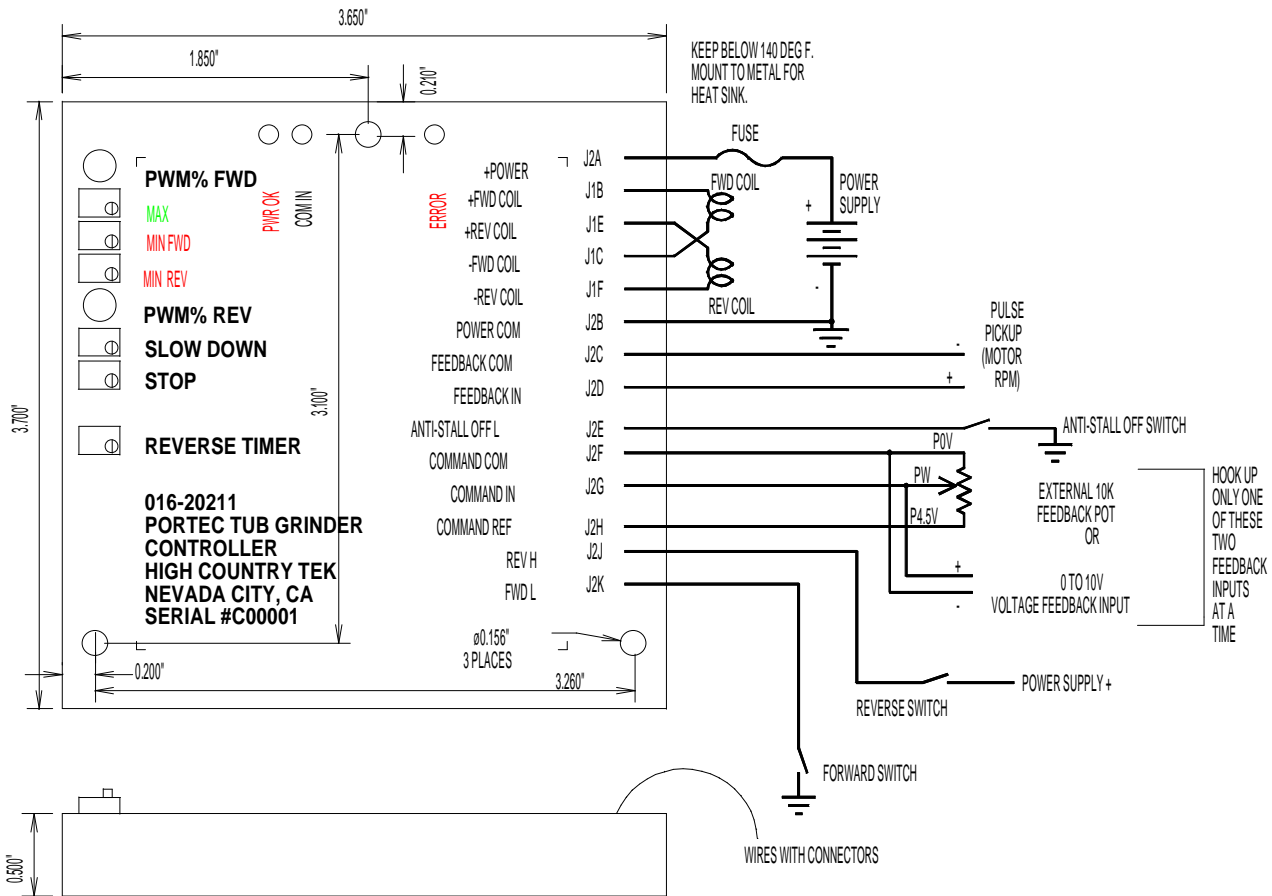

### Portec Tub Grinder Closed Loop Controller 016-20211



### Description of the Portec Tub Grinder Closed Loop Controller

The Portec Tub Grinder Controller drives a dual coil valve to control the rotational speed of a tub. A Radio Remote or external Manual Pot is used to command the desired current to the valve. The Closed Loop Controller provides current regulation to compensate for power supply fluctuation and coil resistance changes. Forward, Reverse and Stop buttons allow the user to change the direction of rotation, or start the tub in the desired direction, or stop the tub. The tub's rotation is automatically reversed under control of a user adjustable timer. A pulse pickup is used to monitor the motor's RPM. The controller will begin to reduce the current to the valve when the RPM drops below the Slow Down setting. The coil current linearly decreases to the minimum current setting as the RPM drops to the Stop setting. If the tub speed decreases to the Stop RPM setting, the controller will automatically restart the tub in the opposite direction.

### Features

1. **Coil Current range:** 0 to 1A.
2. **Valve Driver controls:** The MAX, MIN FWD and MIN REV onboard 10 turn pots are used to setup the minimum and maximum currents commanded by the input controls. The radio input is scaled appropriately so that the same MIN and MAX settings will work for both.
3. The MIN settings have a range of 0 to 1A and controls the current that occurs in response to the minimum command inputs.
4. The MAX setting has a range of 0 to 1A and controls the current that occurs in response to the maximum command inputs.
5. The ERROR LED will flash if the unit has been adjusted so that there can be no change in the output when the input voltage goes from minimum to maximum. If the MIN setting is greater than the MAX, the unit will stay at the MIN value.

High Country Tek ? Electronic Solutions for Industry  
 208 Gold Flat Court ? Nevada City, CA 95959 ? Tel. (530) 265-3236 ? Fax (530) 265-3275

[www.highcountrytek.com](http://www.highcountrytek.com)

Copyright, High Country Tek, Inc. 2002



6. **Optical Interface characteristics:** High Country Tek's OPTOLINK and set-up software (for use with a PC) can be used for a computer interface to the Closed Loop Controller. This interface can be used in trouble shooting the system. The OPTOLINK can be used to read out the values of the onboard pots for future reference or to set them to an exact value; or to over ride the onboard pots for ease of development. Calibration data can be saved or altered.
7. **Indicators:** The following LEDs are located on the Closed Loop Controller.
  - A. PWM% FWD and PWM% REV. These LEDs changes from all red at fully off (0A) to all green at fully on (maximum possible current). The LEDs are off if their coil is not being driven. A flashing green / off LED indicates an open coil and a flashing red / off LED indicates a shorted coil.
  - B. A red PWR OK indicator comes on if the power supply is within the specified range for correct operation, +8Vdc to +30Vdc.
  - C. A red ERROR indicator comes on if an error condition has been detected.
  - D. The COM IN is an optical input for the OPTOLINK and will never glow.
8. **Valve Current Command input:** A COMMAND COM ground terminal is provided for hooking to the ground of the Radio Remote, and the CCW pin of the pot. An external Manual / Remote DPDT switch selects between the radio input and the Manual Pot for setting the tub speed. The DPDT determines which device is hooked to the COMMAND IN pin, (as well as connecting the CW terminal of the Manual Pot to COMMAND REF when it is selected). The Manual Pot must be a 10Kohm value, resulting in 0 to +4.5Vdc at the COMMAND IN pin. The radio remote provides 0 to 10Vdc at the COMMAND IN pin.
9. The Closed Loop Controller detects current drawn from the COMMAND REF terminal to determine if the Manual Pot has been selected. If the pot's CW or CCW wires become broken, the Radio Remote input range will automatically be selected.
10. The Closed Loop Controller will detect a broken wiper lead on the Manual Pot when it is selected. The controller will turn on the error LED and go to minimum current.
11. **Engine RPM sensor:** Interfaces to a two-wire Wabash variable reluctance sensor, P/N 60-0115-107. Maximum speed is 1400 RPM and there are 72 teeth on the pickup sprocket. This input is connected to the controller's FEEDBACK IN input. A FEEDBACK COM terminal on the Closed Loop Controller provides ground for the sensor.
12. **Reversing Timer:** After rotating in the same direction longer than the adjustable Reversing Timer's period, the Tub will stop and reverse direction of rotation. The timer range includes 1 to 10 minutes. The REVERSE TIMER onboard 10-turn pot sets this function.
13. **Forward, Stop and Reverse Inputs:** The Forward and Reverse switches are momentary SPST. The Forward switch is connected to the FWD L input and is pulled up to 5V on the Closed Loop Controller card; the switch pulls it to ground for actuation. The Reverse input will be connected to the REV H input that is pulled down to ground on the Closed Loop Controller card; the switch pulls it up to 24 volts. The Stop switch is a momentary DPDT that causes the Forward and Reverse switch inputs to appear to have been simultaneously pressed by grounding the FWD L input and hooking the REV H input to 24 volts.
14. Pressing the Forward switch will cause the tub to go forward. If the tub was going in reverse, it will ramp to a stop and then ramp to the commanded forward speed.
15. Pressing the Reverse switch will cause the tub to go in reverse. If the tub was going forward, it will ramp to a stop and then ramp to the commanded reverse speed.
16. Pressing the Stop switch will have no effect if the tub is stopped. If the tub was moving, the tub will ramp to a stop.
17. **Ramps:** There are Ramp Down and Ramp Up settings to determine how fast the tub starts and stops when the Reversing Timer or the Forward, Stop or Reverse switches are activated. The Ramp Up timer is also used when restarting after the anti-stall feature has stopped the tub. These ramps are set by OPTOLINK. The range includes 1 to 10 seconds.
18. **Anti-Stall:** The Closed Loop Controller will start to decrease the current to the valve when the engine RPM drops below the Slow Down setting. The current value will be decreased to zero by the time the RPM reaches the Stop setting.
19. **Anti-Stall control pots:** The Slow Down and Stop RPM setpoints are controlled by two onboard 10 turn pots. Full CCW translates to the minimum usable RPM (400 RPM) and full CW translates to maximum usable RPM (1500 RPM).
20. The Controller will not allow the Stop Setting to be more than the Slow Down setting. The ERROR LED will flash if the Stop Setting is adjusted to be greater than the Slow Down Setting. The Stop setting will be equal to the Slow Down Setting while this condition exists.
21. The tub is assumed to have stopped when the coil current reaches zero. At this point the controller will restart the tub in the opposite direction in an attempt to clear a jam.
22. This Anti-Stall process may be over ridden by the user controls. The Forward, Reverse and Stop switches will cause their normal actions. Raising or lowering the commanded current will affect the current output of the Anti-Stall process.



**23. Anti-Stall Off Low:** The Anti-Stall Off Low input disables the Anti-Stall features when it is switched to ground. The effect is the same as temporarily turning down the Slow Down and Stop settings to 0 RPM. This input will “float” to 5 V when not pulled down.